

**Slovak University of Technology in Bratislava
Institute of Information Engineering, Automation, and Mathematics**

PROCEEDINGS

17th International Conference on Process Control 2009

Hotel Baník, Štrbské Pleso, Slovakia, June 9 – 12, 2009

ISBN 978-80-227-3081-5

<http://www.kirp.chtf.stuba.sk/pc09>

Editors: M. Fikar and M. Kvasnica

Paulusová, J., Dúbravská, M.: Fuzzy Logic Autotuning Methods for Predictive Controller, Editors: Fikar, M., Kvasnica, M., In *Proceedings of the 17th International Conference on Process Control '09*, Štrbské Pleso, Slovakia, 397–401, 2009.

Full paper online: <http://www.kirp.chtf.stuba.sk/pc09/data/abstracts/010.html>

FUZZY LOGIC AUTOTUNING METHODS FOR PREDICTIVE CONTROLLER

J. Paulusová and M. Dúbravská

*Institute of Control and Industrial Informatics,
Faculty of Electrical Engineering and Information Technology,
Slovak University of Technology,
Ilkovičova 3, 812 19 Bratislava, Slovak Republic
e-mail: jana.paulusova@stuba.sk, maria.dubravska@stuba.sk*

Abstract: In this paper a new method for predictive auto-tuning PID fuzzy logic controller (predictive FPID) is proposed, analyzed and tested. The paper contains theoretical as well as practical part and offers a new approach to control design and its successful application. The proposed predictive controller is used to control nonlinear process. The results show that the proposed algorithm is capable of an effective control.

Keywords: fuzzy control, nonlinear systems, PID control, predictive control.

1 INTRODUCTION

The PID algorithm is both simple and reliable, and has been applied to thousands of control loops in various industrial applications over the past 60 years (89%-90% of applications). However, not all industrial processes can be controlled using conventional PID algorithms.

Concept of the model based predictive control (MBPC) has been heralded as one of the most significant control developments in recent ten years. The wide range of choice of model structures, prediction horizon, and optimization criteria allows the designer to easily tailor MBPC to his application in industry.

In this paper method for auto-tuning of a SISO predictive controller is proposed and advanced for nonlinear process.

The paper is organized as follows. First, auto-tuning of fuzzy PID controller (FPID) is described in Section 2. Design of predictive FPID is presented in Section 3. The reliability and effectiveness of the presented method is shown on the case study in Section 4 - control of the concentration in chemical reactor by manipulating its inlet flow rate. Summary and conclusions are given in Section 5.

2 AUTOTUNING OF FUZZY PID CONTROLLER

Since the proposed controller uses nonlinear fuzzification algorithm and output membership functions, the controller can be considered as a nonlinear PID where parameters are tuned on-line based on error $e(t)$ and change of error $\Delta e(t)$ compared to set-point $w(t)$ (Almeida, *et al*, 2002).

The system error is compensated by a set of fuzzy linguistic rules which are derived from the experience and knowledge of a control designer on how the behavior of gain and phase margins can be used to compensate the system error efficiently. It can be interpreted as a fuzzy gain scheduling PID controller. Fuzzy logic controller system for nonlinear process is shown in Figure 1, where $u(t)$ is control output.

Firstly, identification of a process model and design of a conventional PID is necessary to be done as a starting point. After that, the fuzzy engine is designed.

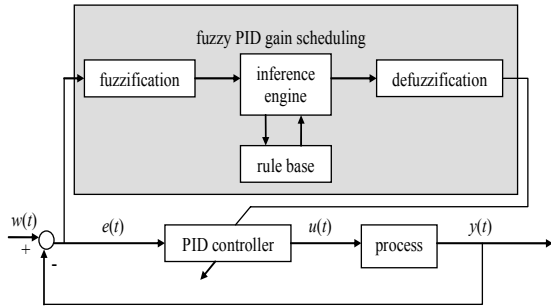

Figure 1 Fuzzy logic controller (FPID) system for SISO system

2.1 Identification of process and initial PID parameters

An approximated model for the process is considered as a second order transfer function with time delay, which is given by

$$G_p(s) = \frac{1}{a_2s^2 + a_1s + a_0} e^{-Ds} \quad (1)$$

Where a_2 , a_1 , a_0 and D are unknown parameters and they need to be determined by a feedback relay experiment. Depending on a_2 , a_1 , a_0 the model may have real or complex poles and it is representing both monotonic and oscillatory processes. Under relay experiments, the parameters are given by

$$a_0 = \frac{1}{K_p}, \quad a_1 = \frac{\sin(\omega_u d)}{\omega_u K_u} \quad (2)$$

$$a_2 = \frac{c + \frac{\cos(\omega_u d)}{K_u}}{\omega_u^2}$$

$$G_p(j\omega_u) = -\frac{1}{K_u} = \frac{\int_0^{t_u} y_r(t) e^{-j\omega_u t} dt}{\int_0^{t_u} u_r(t) e^{-j\omega_u t} dt} \quad (3)$$

Where $y_r(t)$ is process output and $u_r(t)$ is relay output. K_u is process critical gain and ω_u is frequency.

The initial PID parameters are determined considering the following transfer function

$$G_c(s) = k \left(\frac{As^2 + Bs + C}{s} \right) \quad (4)$$

Where $A=K_d/k$, $B=K_c/k$, $C=K_i/k$. The PID gains are K_c , K_i , K_d . Zeros of the controller are chosen to cancel the poles of the process model, $A=a_2$, $B=a_1$, $C=a_0$.

$$G_p(s)G_c(s) = \frac{k}{s} e^{-Ds} \quad (5)$$

Where k is obtained by considering the gain A_m and phase margin Φ_m . The following relation can be derived

$$\Phi_m = \frac{\pi}{2} \left(1 - \frac{1}{A_m} \right) \quad (6)$$

A typical value is $A_m=3$ and $\Phi_m=60^\circ$. The PID parameters are

$$\begin{bmatrix} K_c \\ K_i \\ K_d \end{bmatrix} = \frac{\pi}{2A_mD} \begin{bmatrix} a_1 \\ a_0 \\ a_2 \end{bmatrix} \quad (7)$$

2.2 Auto-tuning fuzzy logic controller engine

The gain and phase margins are considered to be linguistic variables whose values are defined with respect to the same universe of discourse specified by human expertise about the operational knowledge of the process. It is assumed that the feedback system gain and phase margins are in prescribed ranges. Values of A_m and Φ_m are normalized

$$A'_m = \frac{(A_m - A_{m,\min})}{(A_{m,\max} - A_{m,\min})} \quad (8)$$

$$\Phi'_m = \frac{(\Phi_m - \Phi_{m,\min})}{(\Phi_{m,\max} - \Phi_{m,\min})} \quad (9)$$

where A'_m and Φ'_m are normalized gain and phase margins, respectively. Values of A'_m are determined by a set of fuzzy rules of the form

$$\text{If } e(t) \text{ is } A_i \text{ and } \Delta e(t) \text{ is } B_i \text{ then } A'_{m,i} \text{ is } C_i \quad (10)$$

where $i=1, \dots, n$, $A_{m,i}$ is the gain margin for i -rule and A_i , B_i , C_i are fuzzy sets on the corresponding supporting sets.

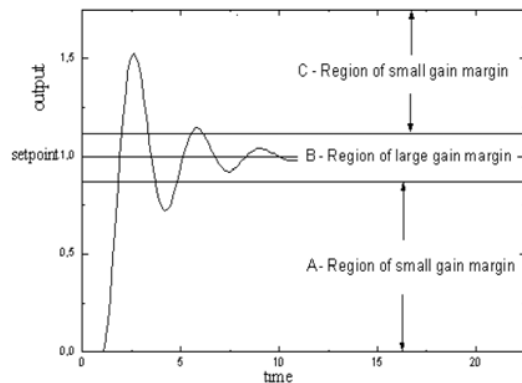

Figure 2 Process response and regions of gain margin

Figure 2 shows an example of a desired time response of the process.

The membership functions are shown in Figure 3.

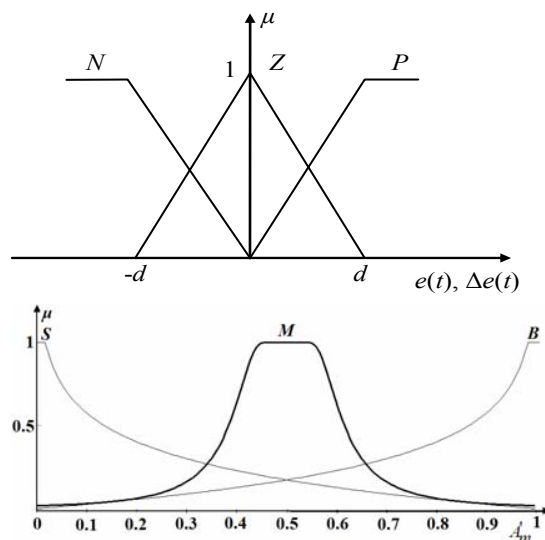

Figure 3 Membership functions for input and output variables

Where the fuzzy set C_i may be S -small, M -medium, B -big and it is characterized by logarithmic membership functions (11-13).

The degree of the membership μ and the variable A'_m are (Almeida, *et al.*, 2002)

$$\mu_B(A'_m) = -\frac{1}{\eta} \ln(1 - A'_m) \quad (11)$$

$$\mu_M(A'_m) = 1 - e^{-(\delta/|0.5 - A'_m|)^{2.5}} \quad (12)$$

$$\mu_S(A'_m) = -\frac{1}{\eta} \ln \mu_M(A'_m) \quad (13)$$

The adjustable parameters are η and δ . Based on μ_i , values of A'_m for each rule are determined from their correspondent membership function.

This theory for linear model has been extended for the nonlinear process. For control it is very important to set $A_{m,min}$ and $A_{m,max}$. These values have effect on the quality of control.

3 PREDICTIVE CONTROL

The proposed predictive fuzzy control system is shown in Figure 4 (Paulusová, *et al.* 2006). It is composed of a fuzzy model (ANFIS) and FPID.

In Figure 4, $w(t)$ is the reference variable $y(t)$ is nonlinear plant output, $u(t)$ is control input of the plant, $u(t)$ is output of the controller and $\hat{y}(t)$ is predicted value of y based on the predictive fuzzy model.

To achieve the objective of predictive control, the fuzzy model has been used as a predictor to predict $\hat{y}(t)$.

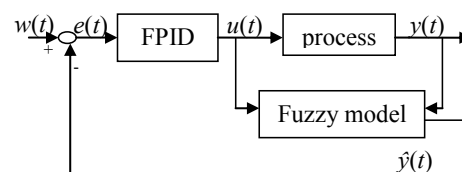
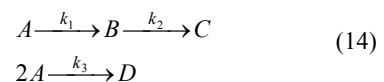

Figure 4 Proposed predictive fuzzy control system

4 CASE STUDY AND SIMULATION RESULTS

4.1 Case study

The application considered involves an isothermal reactor in which the Van Vusse reaction kinetic scheme is carried out. In the following analysis, A is the educt, B the desired product, C and D are unwanted byproducts.



From a design perspective the objective is to make k_2 and k_3 small in comparison to k_1 by appropriate choice of catalyst and reaction conditions. The concentration of B in the product may be controlled by the manipulating the inlet flow rate and/or the reaction temperature.

The educt flow contains only cyclopentadiene in low concentration, C_{Af} . Assuming constant density and an ideal residence time distribution within the reactor, the mass balance equations for the relevant concentrations of cyclopentadiene and of the desired product cyclopentanol, C_A and C_B , are as follows:

$$\begin{aligned} \dot{C}_A &= -k_1 C_A - k_3 C_A^2 + \frac{F}{V} (C_{Af} - C_A) \\ \dot{C}_B &= k_1 C_A - k_2 C_B - \frac{F}{V} C_B \\ y &= C_B \end{aligned} \quad (15)$$

This example has been considered by a number of researchers as a benchmark problem for evaluating nonlinear process control algorithm.

By normalizing the process variables around the following operating point and substituting the values for the physical constants, the process model becomes:

$$\begin{aligned} \dot{x}_1(t) &= -50x_1(t) - 10x_1^2(t) + u(10 - x_1(t)) \\ \dot{x}_2(t) &= 50x_1(t) - 100x_2(t) + u(-x_2(t)) \\ y(t) &= x_2(t) \end{aligned} \quad (16)$$

where the deviation variable for the concentration of component A is denoted by x_1 , the concentration of component B by x_2 , and the inlet flow rate by u .

The simulation scheme of this process is in Figure 5 (Paulusová, *et al.* 2007).

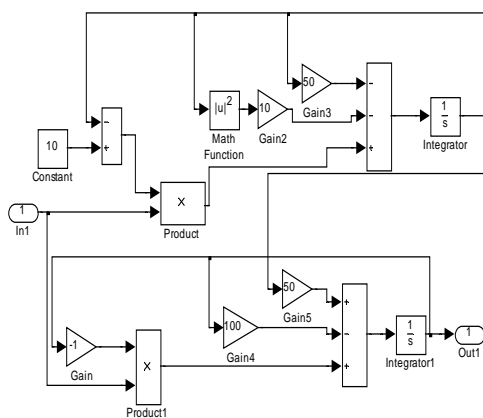

Figure 5 Simulation scheme for the nonlinear process described by (16)

4.2 Fuzzy model

Fuzzy model was created in ANFIS editor (in MATLAB). The model has two inputs and each of them has five triangular membership functions.

Number of rules is 25. The comparison of process and its fuzzy model is shown in Figure 6.

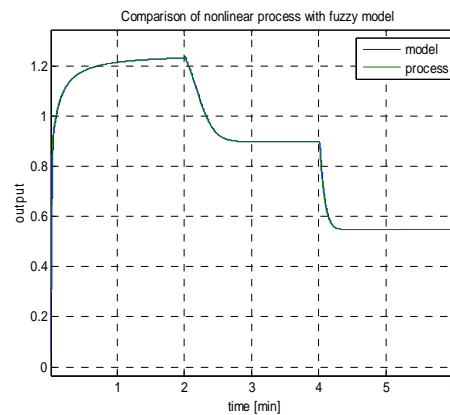

Figure 6 Comparison of fuzzy model and nonlinear process

4.3 Predictive control

Fuzzy controller is designed for a nonlinear process given by (16). The fuzzy controller has three membership functions.

The membership functions for input (e , Δe) and output (A_m) variables are shown in Figure 4. The rule base of the fuzzy controller is shown in Table 1. The fuzzy controller is designed with nine rules.

		$\Delta e(t)$		
		N	Z	P
$e(t)$	N	S	M	S
	Z	M	B	M
	P	S	M	S

N-negative, Z-zero, P-positive
 S-small, B-big, M-medium

Table 1 Rule base

The relay feedback experiment is used to tune PID parameters around an operational point. The time responses of the controlled and reference variables of the nonlinear process controlled by predictive FPID (Figure 4) is shown in Figure 7.

The performance of the control by predictive FPID is also depended on a suitable choice of A_m . Detailed procedure of A_m choice is part of future work.

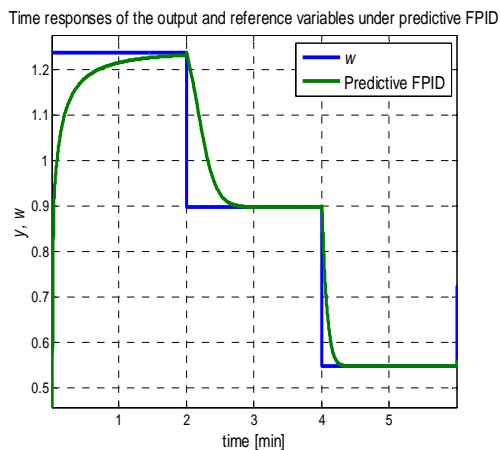

Figure 7 Time responses of the controlled and reference variables of the nonlinear process under predictive FPID with $A_m \in \langle 0.747; 2.253 \rangle$

5 CONCLUSIONS

In this paper a fuzzy logic auto-tuning methods for predictive PID controller parameters have been applied to the concentration control in the chemical reactor by manipulating its flow rate.

The performance of predictive FPID controller is dependant on a suitable choice of A_m parameter.

ACKNOWLEDGEMENT

This paper has been supported by the Slovak Scientific Grant Agency, Grant No. 1/0544/09.

6 REFERENCES

- ALMEIDA, O.M.; COELHO, A.A.R. 2002. A fuzzy logic method for autotuning a PID controller: SISO and MIMO systems. In.: *2002 IFAC 15th Triennial World Congress*, Barcelona, Spain, 3031.
- PAULUSOVÁ, J.; KOZÁK, Š. 2006. Robust Predictive Fuzzy Control. In.: *7th Portuguese Conference on Automatic Control, CONTROLO'2006*, Lisbon, Portugal: 11-13 September 2006, MA-7-1. ISBN.
- PAULUSOVÁ, J.; KOZÁK, Š.; DÚBRAVSKÁ, M. 2007. Fuzzy logic autotuning methods for PID controller applied to nonlinear process. In.: *16th International Conference on Process Control 2007, Process Control '07*, Štrbské pleso, Slovakia: 11-14 June 2007, 177s.pdf. ISBN.