

**Slovak University of Technology in Bratislava  
Institute of Information Engineering, Automation, and Mathematics**

**PROCEEDINGS**

**17<sup>th</sup> International Conference on Process Control 2009**

**Hotel Baník, Štrbské Pleso, Slovakia, June 9 – 12, 2009**

**ISBN 978-80-227-3081-5**

**<http://www.kirp.chtf.stuba.sk/pc09>**

**Editors: M. Fikar and M. Kvasnica**

Skočák, P., Hruška, F.: New Aspects of Small Electric Input Power Measurement, Editors: Fikar, M., Kvasnica, M., In *Proceedings of the 17th International Conference on Process Control '09*, Štrbské Pleso, Slovakia, 259–262, 2009.

Full paper online: <http://www.kirp.chtf.stuba.sk/pc09/data/abstracts/019.html>

## NEW ASPECTS OF SMALL ELECTRIC INPUT POWER MEASUREMENT

P. Skočik and F. Hruška

*Tomas Bata University in Zlín, Faculty of Applied Informatics  
Nad Stráněmi 4511, 760 05 Zlín, Czech Republic  
fax: +420 576 032 717 and e-mail: skocik@fai.utb.cz, hruska@fai.utb.cz*

**Abstract:** The paper is focused on the small electric input power measurement for research and study of material machining. The requirement is to have the measurement with high accuracy and sensitivity. The commercial devices for measuring the electric input/output power are available only for wide ranges. Therefore, an analog device for electric input power measurement was developed. The new demand is to redesign the circuit for enhancing the sensitivity. Measurement of high electric input power values is changed to the measurement of their differences with reference value. The device consists of analog operational amplifiers and analog multiplier unit of effective electric current and voltage.

**Keywords:** effective input power, low input power, input power difference.

### 1 INTRODUCTION

The device for measuring the low electric power was constructed to solve a specific problem of polymer materials machining. It helps to prove the material suitability for this process. The main parts of the process are compared during the dynamic machining, e.g. cutting resistance, gyroscopic moment or power requirement of cutting engine. Generally, there are two possibilities how to determine cutting resistance. It is possible to take advantage of the exact understanding of the system. Then analytical dependences can be used. Second option is usage of more accurate indirect method based on measuring the power requirement of the cutting machine. The cutting force can be determined from this requirement after some mathematical operations.

This is one example why to measure small electric effective power. Naturally, engineering practice knows quite large number of special applications dealing with the same problem – how to measure small electric effective power. There are situations when commercial measuring devices cannot be used e.g. dynamic and static watt-meters. They are usually unsuitable due to their wide range and small accuracy. On the contrary, this measurement requires high accuracy and sensitivity.

### 2 CIRCUIT DESIGN

The designed circuit for indirect cutting resistance measurement is based on simple balance equation. Total electric input power  $P_c$  is equal to sum of power lost in drive unit  $P_p$  and power spent for cutting  $P_o$  (Hruška *et al.* 2004).

$$P_c = P_p + P_o = k.U.I.\cos\varphi \quad (1)$$

where:  $k$  – conversion constant (-),  $U$  – effective value of supply voltage (V),  $I$  – effective value of current (A),  $\varphi$  – phase shift (rad).

Electric input power can be obtained from equation (1) if the input voltage  $U$ , current  $I$  and phase shift  $\varphi$  are measured.

Proposed solution is shown in Fig. 1. The input phase voltage  $U_{1,ef}$  and current  $I_{1,ef}$  go through multiplier into effective-value to DC-voltage conversion unit and then into output amplifier. The output value is unified signal  $U_{out}$  in range from 0 to 10 V DC. This output voltage is proportional to the alternate electric effective power. Phase shift is omitted in this method (Hruška *et al.* 2004).

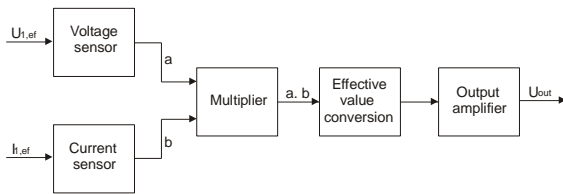

Fig. 1. Block circuit diagram for small electric input power evaluation

Scanning and amplifying of electric current and voltage effective values is shown in Fig. 2. This figure demonstrates the impedance match and separation via small transformers and amplification via operational amplifiers. Single-phase electric current flows through the supply wire which cause voltage decrease in shunt resistor. This sinusoidal alternate power supply voltage is separated, subsequently transformed via transformer TR<sub>I</sub> and connected to the amplifier. It provides voltage equal to the value of effective electric current I<sub>ef</sub> (Hruška *et al.* 2004).

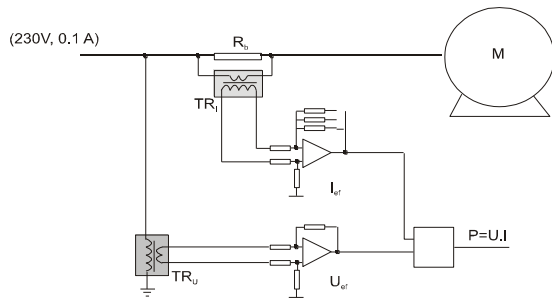

Fig. 2. The circuit for effective voltage and current measurement and small electric power input evaluation

Similar method is used to connect additional voltage measuring part. Separation and impedance match is again designed via transformer TR<sub>U</sub> and circuit with operational amplifier which produces voltage U<sub>ef</sub> proportional to measured variable.

The circuit AD633JN from Analog Devices was used as the multiplying unit for analog values. The principle of this integrated circuit can be seen in Fig. 3.

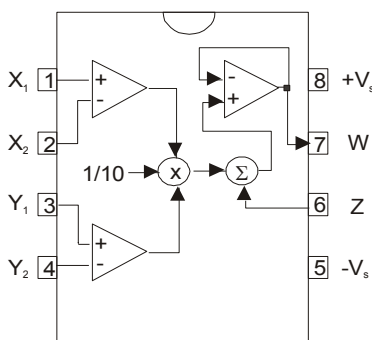

Fig. 3. Integrated circuit AD633

AD633 is a high precision analog multiplier. The mathematical function of the circuit is:

$$W = \frac{(X_1 - X_2) \cdot (Y_1 - Y_2)}{10V} + Z \quad (2)$$

Conversion of the effective value after the multiplication is depicted in Fig. 4. Common effective value is given by:

$$Y_s = \sqrt{\frac{1}{T} \int_0^T y^2 \cdot dt} \quad (3)$$

For the harmonic signal it can be computed from the equation:

$$Y_s = \frac{1}{\sqrt{2}} Y_{\max} \quad (4)$$

The conversion in analog methods is usually realized with circuit containing operational amplifiers. Analog converter for effective voltage values (Fig. 4) transforms values of alternate voltage U<sub>s</sub> into direct value U<sub>o</sub>. However, this conversion is highly inaccurate.

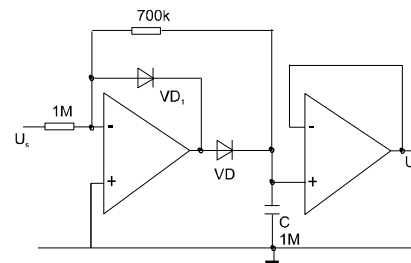

Fig. 4. The circuit for effective values measurement

### 3 CIRCUIT FOR SMALL INPUT POWER MEASUREMENT – REVISION 2

The design of the circuit revision 2 is based on the reconstruction of the original circuit (Skočík *et al.* 2005) for small electric input power measurement. Results from measurements on the former circuit showed the suitability of the method for small electric input power measurement. The positive features are linearity, acceptable sensitivity and repeatability of measurements. However, there are also disadvantages such as:

- part of the measurement is using bridge connection and rectification which may not produce the value of U<sub>ef</sub>,
- resistor shut is heated up extremely,
- small output range (from -0,8 to 0,8V), the whole range +/- 10V is not used,
- wide difference in the range 250-300 W.

These negative points were the reason for the construction changes in revision 2. This new version of the circuit is shown in Fig. 5. It was also published (Skočík *et al.* 2006).

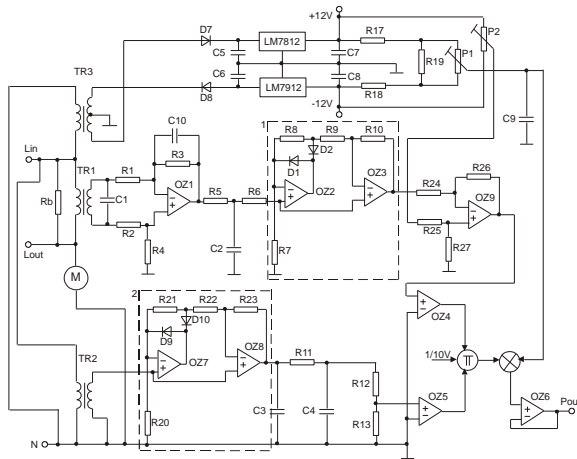

Fig. 5. Circuit diagram revision 2 for difference of small electric input power measurement

#### 4 VERIFICATION AND REDESIGN OF THE CIRCUIT REVISION 2

The program environment Micro-Cap, which serves for the electronic circuit analysis, was used for the verification.

The simulation was focused on verification of the circuit parts for measurement of effective values. These parts are highlighted in Fig. 5. The circuit for current measurement (block number 1) and voltage measurement (block number 2).

The simulation was performed for both parts separately. Results from the simulation showed that the output is not the voltage/current effective value, but only the rectified one. Due to this fact, both blocks (1 and 2) need to be reconstructed and replaced by different circuits.

The redesign of the mentioned parts can be seen in Fig. 6. The parts from Fig. 5 were replaced by the integrated circuit AD637 (Analog 2007). This circuit transforms the harmonic signal to its effective value.

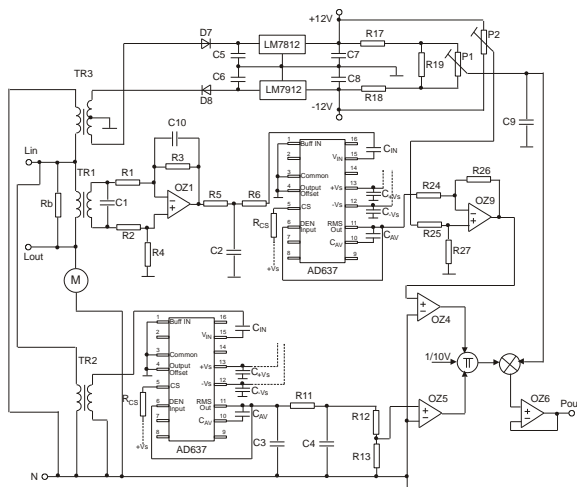

Fig. 6. Revision 3 of the circuit for difference of small electric input power measurement

The proper function of the integrated circuit AD637 was verified by developing and constructing the testing circuit (Fig. 7) and measuring in laboratory environment. The results from the measurement are shown in Table 1. Because the AD637 circuit is not available in Micro-Cap, it was replaced by the mathematical function.

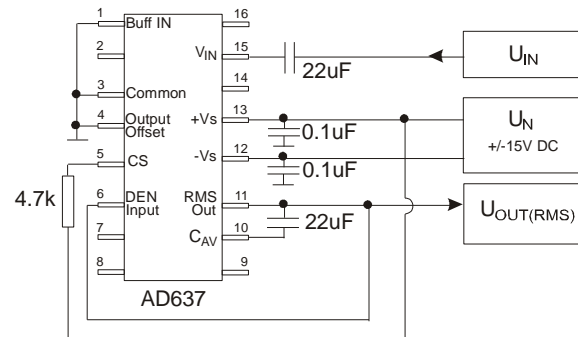

Fig. 7. Scheme of the testing circuit

The function of the AD637 was verified for the sine wave, square wave and triangular wave of the input signal  $U_{IN}$  with 50 Hz frequency. It is necessary to underline, that the input signal  $U_{IN}$  in the following tables represents the amplitude of the signal and not the effective value. Further, the input signal to the AD637 is in range from 0.1 to 2.0 V AC. Assumed utilization of the circuit revision 3 with AD637 is for the sine wave with 50 Hz frequency. Therefore, the table 1 is presented for wider measurement range than the tables 2 and 3. Multimeter Metex M-3860M was used for the comparison measurement. The effective values  $U_{OUT(RMS)}$  from AD637 and M-3860M were compared with the theoretical value. Their absolute  $\Delta U_{OUT(RMS)}$  and relative  $\delta U_{OUT(RMS)}$  errors are again shown in Table 1.

Some chosen values from the measurement of square and triangular waves are shown in tables 2 and 3 for the illustration.

Table 1. Effective values  $U_{OUT(RMS)}$  for sine wave  $U_{IN}$

#	$U_{IN}$ (mV) ETC M631	$U_{OUT(RMS)}$ (mV) AD637	$U_{OUT(RMS)}$ (mV) M-3860M	$U_{OUT(RMS)}$ (mV) calculated
1	100	70,1	65,8	70,7
2	200	140,7	137,6	141,4
3	300	211,3	209,1	212,1
4	400	282,1	281,4	282,8
5	500	352,8	353,0	353,6
6	600	423,0	424,0	424,3
7	700	494,0	495,0	495,0
8	800	562,0	563,0	565,7
9	900	631,0	635,0	636,4
10	1000	701,0	705,0	707,1
11	1100	771,0	777,0	777,8
12	1200	843,0	850,0	848,5
13	1300	913,0	922,0	919,2
14	1400	984,0	994,0	989,9
15	1500	1055,0	1066,0	1060,7
16	1600	1125,0	1137,0	1131,4

17	1700	1197,0	1212,0	1202,1
18	1800	1267,0	1282,0	1272,8
19	1900	1338,0	1354,0	1343,5
20	2000	1408,0	1425,0	1414,2
#	$\Delta U_{OUT(RMS)}$ (mV) AD637	$\Delta U_{OUT(RMS)}$ (mV) M-3860M	$\delta U_{OUT(RMS)}$ (%) AD637	$\delta U_{OUT(RMS)}$ (%) M-3860M
1	0,6	4,9	0,8	6,9
2	0,7	3,8	0,5	2,7
3	0,8	3,0	0,4	1,4
4	0,7	1,4	0,2	0,5
5	0,8	0,6	0,2	0,2
6	1,3	0,3	0,3	0,1
7	1,0	0,0	0,2	0,0
8	3,7	2,7	0,6	0,5
9	5,4	1,4	0,8	0,2
10	6,1	2,1	0,9	0,3
11	6,8	0,8	0,9	0,1
12	5,5	-1,5	0,6	-0,2
13	6,2	-2,8	0,7	-0,3
14	5,9	-4,1	0,6	-0,4
15	5,7	-5,3	0,5	-0,5
16	6,4	-5,6	0,5	-0,5
17	5,1	-9,9	0,4	-0,8
18	5,8	-9,2	0,5	-0,7
19	5,5	-10,5	0,4	-0,8
20	6,2	-10,8	0,4	-0,8

Table 2. Effective values  $U_{OUT(RMS)}$  for square wave  $U_{IN}$

#	$U_{IN}$ (mV) ETC M631	$U_{OUT(RMS)}$ (mV) AD637	$U_{OUT(RMS)}$ (mV) M-3860M	$U_{OUT(RMS)}$ (mV) calculated
1	500	499,0	499,0	500,0
2	1000	992,0	996,0	1000,0
3	1500	1492,0	1504,0	1500,0
4	2000	1991,0	2008,0	2000,0
#	$\Delta U_{OUT(RMS)}$ (mV) AD637	$\Delta U_{OUT(RMS)}$ (mV) M-3860M	$\delta U_{OUT(RMS)}$ (%) AD637	$\delta U_{OUT(RMS)}$ (%) M-3860M
1	1,0	1,0	0,2	0,2
2	8,0	4,0	0,8	0,4
3	8,0	-4,0	0,5	-0,3
4	9,0	-8,0	0,4	-0,4

Table 3. Effective values  $U_{OUT(RMS)}$  for triangular wave  $U_{IN}$

#	$U_{IN}$ (mV) ETC M631	$U_{OUT(RMS)}$ (mV) AD637	$U_{OUT(RMS)}$ (mV) M-3860M	$U_{OUT(RMS)}$ (mV) calculated
1	500	288,0	287,0	288,7
2	1000	572,0	576,0	577,4
3	1500	861,0	872,0	866,0
4	2000	1149,0	1166,0	1154,7
#	$\Delta U_{OUT(RMS)}$ (mV) AD637	$\Delta U_{OUT(RMS)}$ (mV) M-3860M	$\delta U_{OUT(RMS)}$ (%) AD637	$\delta U_{OUT(RMS)}$ (%) M-3860M
1	0,7	1,7	0,2	0,6
2	5,4	1,4	0,9	0,2
3	5,0	-6,0	0,6	-0,7
4	5,7	-11,3	0,5	-1,0

## 5 CONCLUSION

This contribution was focused on the verification and reconstruction of the circuit for difference of small electric input power measurement. The main problem with effective value of AC voltage to DC voltage conversion was eliminated. The new path for further research and development of the device was opened.

## REFERENCES

- Hruška, F. and I. Lukovics (2004). Dynamická obrobiteľnosť polymerných materiálov. In: *VI. Medzinárodná vedecká konferencia „ Strojárska technológia 2004 ”*. Súľov, Slovakia : 29. - 30. september 2004, ISBN 80-8070-300-0.
- Skočík, P. and F. Hruška (2005). Analog measurement of electric power / Indirect measuring of machinability. In: *Process Control 2005*. Štrbské Pleso, Slovakia : 7. – 10. June 2005, pp. 167, ISBN 80-227-2235-9.
- Skočík, P. and F. Hruška (2006). Reconstruction of measure device of electric effective power. In: *7th International Carpathian Control Conference 2006*. Rožnov pod Radhoštěm, Czech Republic : 29. – 31. May 2006, pp. 517-520, ISBN 80-248-1066-2.
- Analog Devices. *AD637: High Precision, Wideband RMS-to-DC Converter* [online]. 2007 [cit. 2009-01-26]. Dostupný z WWW: <<http://www.analog.com/en/other/rms-to-dc-converters/ad637/products/product.html>>.